

NEXGEN



Dedicated Outdoor Air Systems



WHAT WE OFFER

Dedicated Outdoor Air Systems

In its simplest form, a dedicated outdoor air system (DOAS) is a type of HVAC system whose primary function is to deliver treated outdoor air into the space it serves. These systems filter the incoming air, remove moisture, and generally reheat the air back to 72°F (or neutral). However, due to the inherent flexibility of the NexGen product line, these units can be designed for dew point control, make up air, and many other applications.

SOLUTIONS FOR TIGHT CONSTRUCTION

Less Pollutants, More Clean Air

Spaces with tight construction need fresh air. As we make our indoor environments tighter, less air flows through them. With less air circulation, pollutants can build up in the space. The pollutants can include carbon dioxide from breathing, smoke from cooking, volatile organic compounds (VOCs) emitted from cleaning materials and consumer products, and moisture, which can lead to mold if not controlled properly.

The only proven, energy-conscious solution is a mechanical ventilation system that delivers treated outdoor air. With an extremely airtight envelope and a mechanical ventilation system that controls exactly where and how much air is delivered, you get the quantity of fresh air you need, deliver the fresh air where it's needed, and you get it no matter the conditions of the outdoor air.

STANDARD AND OPTIONAL FEATURES

NR Compact DOAS Series

- Capacity from 3 - 90 Tons
- Airflow from 750 - 19,000 CFM
- 2" Foam-Injected Double-Wall Construction (R-13)
- Hinged, Double-Walled Access Doors
- 6-Row Intertwined Air Coils
- Modulating Reheat Circuit
- Switchable SubCooling Circuit
- Scroll Compressors (Optional Lead VFD)
- All-Digital Controls with BAS Integration
- Direct Drive EC Plenum Supply Blowers
- Modulating Electric or Gas Heat
- 2500 Hour Salt-Spray Rated Cabinet
- MicroChannel Condenser Coils
- Up to 6" of Media Filtration
- Multiple Service Access Points
- Reduced Cabinet Weight
- Compact Footprint
- Optional 10,000 Hour Corrosion Protection

Solutions for Every Application



Healthcare

When the focus is on healing, patient comfort is critical. NexGen provides fresh air into a variety of healthcare spaces and applications.



Retail

A pleasant shopping experience can increase customers and sales. NexGen products offer grocery store and retail spaces with refrigeration energy savings and effective temperature control.

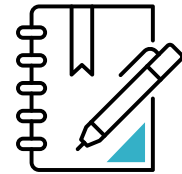

Education

NexGen provides Innovative solutions for changing ventilation needs based on occupancy, time of day, and space usage.



Hospitality

Hotels, restaurants, & fitness centers require an Awesome Customer Experience to be successful. Comfort is key.

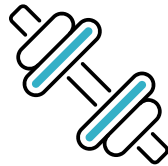

Fitness

IAQ in a fitness facility is important because of the proximity of patrons as well as their increased rate of respiration and perspiration



Offices

From small to large spaces, NexGen offers solutions for all types of office buildings that require controlled outdoor air ventilation.

OUR FAMILY OF PRODUCTS

A Fit for Every Building



1 Series

- Capacity from 3 - 10 Tons
- Airflow: 750 - 2,500 CFM
- Ultra-Small Footprint with Energy Efficient Operation
- 100% OA, Recirculating, Mixed Operation



3 Series

- Capacity from 10 - 25 Tons
- Airflow: 2,500 - 6,250 CFM
- Fits Many Competitor's Footprints with More Capacity
- 100% OA, Recirculating, Mixed Air, Energy Recovery, and Exhaust Operation



5 Series

- Capacity from 20 - 45 Tons
- Airflow: 5,000 - 11,000 CFM
- Small Footprint with Large Heating Capacity
- 100% OA, Recirculating, Mixed Air, Energy Recovery, and Exhaust Operation



7 Series

- Capacity from 45 - 90 Tons
- Airflow: 11,250 - 19,000 CFM
- Fits Many Competitor's Footprints with More Capacity
- 100% OA, Recirculating, Mixed Air, Energy Recovery, and Exhaust Operation

NR Series Dimensions

NR 1 Series Cabinet

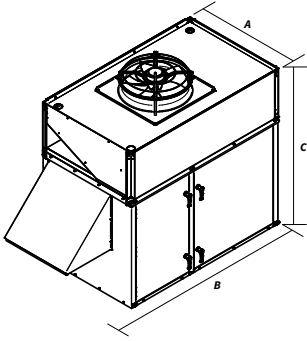

NR 3 Series Cabinet

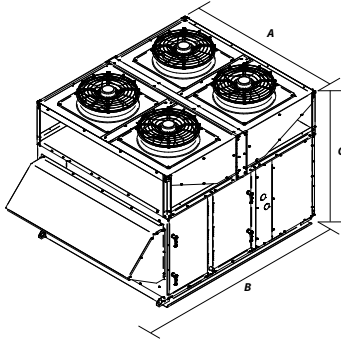

NR 5 Series Cabinet

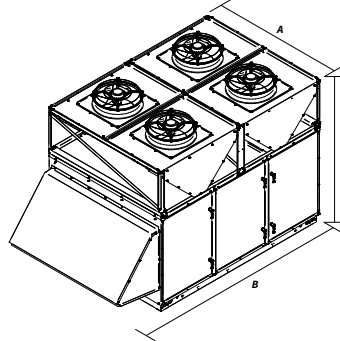

NR 7 Series Cabinet

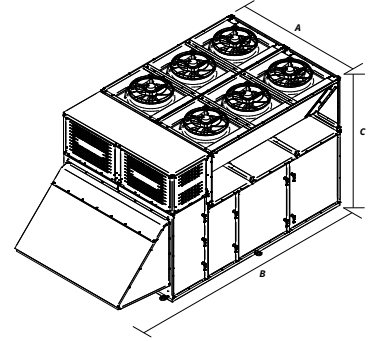

Model:	Maximum Airflow:	Heat Range: (MBH)	Cabinet:	Tonnage:	Length - OA Model: (A)	Length - With Return: (A)	Length - With Wheel: (A)	Width: (B)	Height: (C)
NR*K036	750	up to 150	S1	3	99.25	99.25	129.0	50.625	77.375
NR*K060	1,250	up to 150	S1	5	99.25	99.25	129.0	50.626	77.375
NR*K096	2,000	up to 150	S1	8	99.25	99.25	129.0	50.625	77.375
NR*K118	2,500	up to 150	S1	10	99.25	99.25	129.0	50.625	77.375
NR*K120	2,500	up to 400	S3	10	115.5	136.5	160.625	80.0	77.0
NR*K150	3,125	up to 400	S3	12	115.5	136.5	160.625	80.0	77.0
NR*K180	3,750	up to 400	S3	15	115.5	136.5	160.625	80.0	77.0
NR*K210	4,375	up to 400	S3	18	115.5	136.5	160.625	80.0	77.0
NR*K240	5,000	up to 400	S3	20	115.5	136.5	160.625	80.0	77.0
NR*K299	6,250	up to 400	S3	25	115.5	136.5	160.625	80.0	77.0
NR*K241	5,000	up to 1200	S5	20	151.875	185.125	209.625	85.0	98.0
NR*K300	6,250	up to 1200	S5	25	151.875	185.125	209.625	85.0	98.0
NR*K360	7,500	up to 1200	S5	30	151.875	185.125	209.625	85.0	98.0
NR*K420	8,750	up to 1200	S5	35	151.875	185.125	209.625	85.0	98.0
NR*K540	11,000	up to 1200	S5	45	151.875	185.125	209.625	85.0	98.0
NR*K541	11,250	up to 1200	S7	45	206.75	239.75	271.438	100.0	110.0
NR*K600	12,500	up to 1200	S7	50	206.75	239.75	271.438	100.0	110.0
NR*K660	13,750	up to 1200	S7	55	206.75	239.75	271.438	100.0	110.0
NR*K720	15,000	up to 1200	S7	60	206.75	239.75	271.438	100.0	110.0
NR*K840	17,500	up to 1200	S7	65	206.75	239.75	271.438	100.0	110.0
NR*K960	18,500	up to 1200	S7	80	206.75	239.75	271.438	100.0	110.0
NR*K09T	19,000	up to 1200	S7	90	206.75	239.75	271.438	100.0	110.0

Note: Dimensions will be dependent on option content, and other field added features. Consult final selection drawings for complete details.

